

Smart-Hose™

TECHNOLOGIES

Smart-Hose Break-Away (LL3-B)



Smart-Break-Away Features and Benefits:

- 360 Degree Engineered Break-away point.
- Rugged shock proof design with annular seals.
- Built in Bumper feature.
- 316 SS Schedule 80 construction.
- Integrated to work with the Smart-Hose safety system.
- Re-buildable.
- Custom Engineered break-points for specific applications.
- Meets 5 to 1 burst specifications.
- Currently available in 2" Male NPT or Female NPT.
- Available for both Plant and Transport applications.

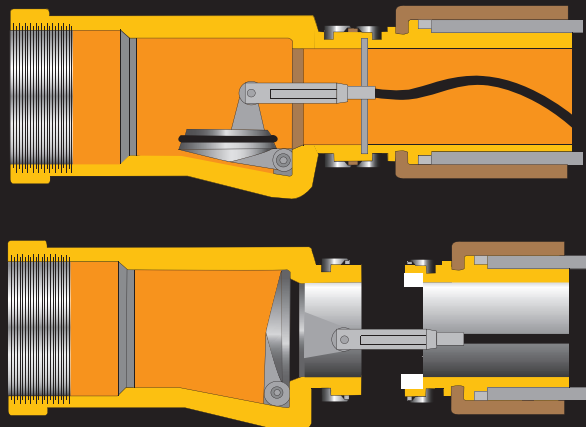

The **Smart-Hose Break-Away** has been designed to protect your plant's piping and bulk-head from pull-away incidents. Designed to integrate with the Smart-Hose safety system and engineered with a predetermined break-point. The Smart-Hose Break-Away can add an additional layer of protection inside your plant and transport hoses while protecting your facility from the devastating consequences of a pull-away accident.

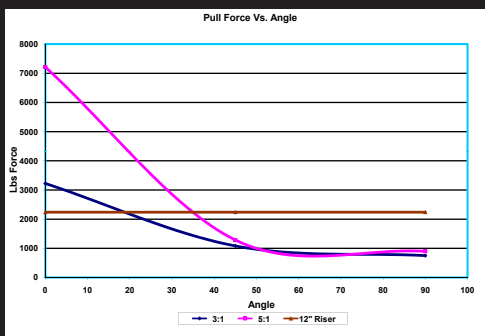

Smart-Hose Technologies manufactures the world's only industrial hose assembly that is engineered with internal valves that are integrated with-in each end fitting. The Smart-Hose safety system is designed to instantaneously shut down the flow in both directions in the event of a catastrophic hose failure. The Smart-Hose safety system is a passive safety system and there-fore, needs no human intervention to activate.

Smart-Hose Technologies

Any Hose, Any Fitting, Any Application...We can make your transfer operation safer!!!

Smart-Hose Technologies • PO Box 16828 • Philadelphia, Pa. 19142

Phone: 215-730-9000 • Fax: 215-730-0558

SMARTHOSE.COM